



PL-WM TRACKSETTER

The crosscountry tracksetter
for motorsleds

■ Bächler Top Track AG
■ Snowtechnology
■ Industriestrasse 3
■ CH-5644 Auw

■ +41 (0)56 677 71 00
■ +41 (0)56 677 71 01
■ www.bachler.ch
■ info@bachler.ch



snowmaking

piste & tracks

fun

PL-WM TRACKSETTER

The PL-WM is very easy to use and has a lot of applications: efficient preparing of skating pistes and classic cross-country tracks, steep downhill and climbs, hiking trails and bridle paths.

The reasonable weight distribution and excellent gliding properties see to it that neither the tractive output nor the maneuverability of the motorsled are impaired.

There are 4 variations of the PL-WM whereof each is retroactively modifiable.

Variation 1 track plate „Schleipfus“

The track plate „Schleipfus“ prepares perfect crosscountry tracks by mild snow conditions.

Variation 2 Renovator and „Schleipfus“

The renovator enhances the performance of the Bächler tracksetter. The renovator is mounted on the motorsled or quad bike. The special angel cutters rip the old track and prepare a new, stable track on the same course. Only one effortless working process for tilling, leveling and preparing the icy and humpy track.

Variation 3 Renovator and Finisher Board

Same as variation 2. The renovator rips the old track and the finisher board prepares a new plane track. This formation is suited for lift lines, skating pistes, hiking trails and bridle paths.

Variante 4 Renovator, Schleipfus and AGV-E

The AGV-E which is mounted on the track plate can be used to lift out the track plate to get a plane track instead of a crosscountry slope. This can be achieved mechanically with a easy hand grip or with a electrical activated lifting spindle. This hardware configuration is used by precipitous climbs and downhill for skating slopes and hiking paths.



Variation 1

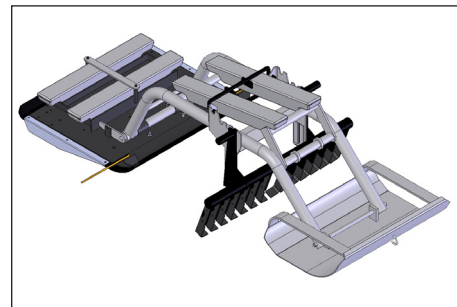

Variation 2

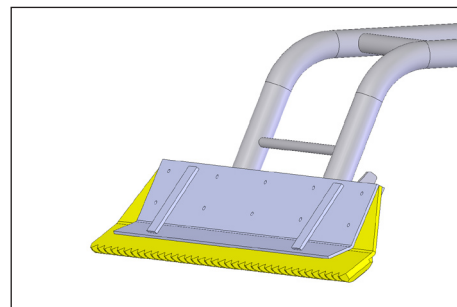

Variation 3

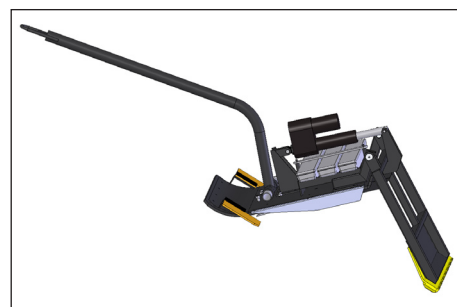

Variation 4